



Introduction

FBs-4DA are two of the analog output modules of FATEK FBs series PLC. They provide 4 and 2 channels 14 bit D/A output respectively. Base on the different jumper settings it can provide varieties of current or voltage output signal. The output code can be configured as unipolar or bipolar which makes the relation of output code and real output signal more intuitive. For safety, the output signal will be automatically forced to zero(0V or 0mA) when the module is not serviced by CPU for 0.5 second

Specifications

Total Channels – 4(4DA)

Resolution- 14 bit

Signal Resolution - 0.3mV(Voltage), 0.61uA(Current)

I/O Points Occupied –

4(4DA) RO(Output Register)

Conversion Time- Updated each scan

Accuracy- $\pm 1\%$

Max. and Min. output loading-

Voltage Output- 500~1M Ω

Current Output- 0~500 Ω

Output Range-

-10~+10V, -5~+5V, 0~10V, 0~5V

-20~+20mA, -10~+10mA, 0~20mA, 0~10mA

Isolation- Transformer(Power) and photo-coupler(Signal)

Indicator(s) - 5V PWR LED

External Power and Consumption-

24V-15%/+20%,

120mA(4DA) or 70mA(2DA) max.

Internal Power Consumption- 5V, 20mA

Operating Temperature- 0 ~ 60 °C

Storage Temperature- -20 ~ 80 °C

Dimensions- 40(W)x90(H)x80(D) mm

Dimensions

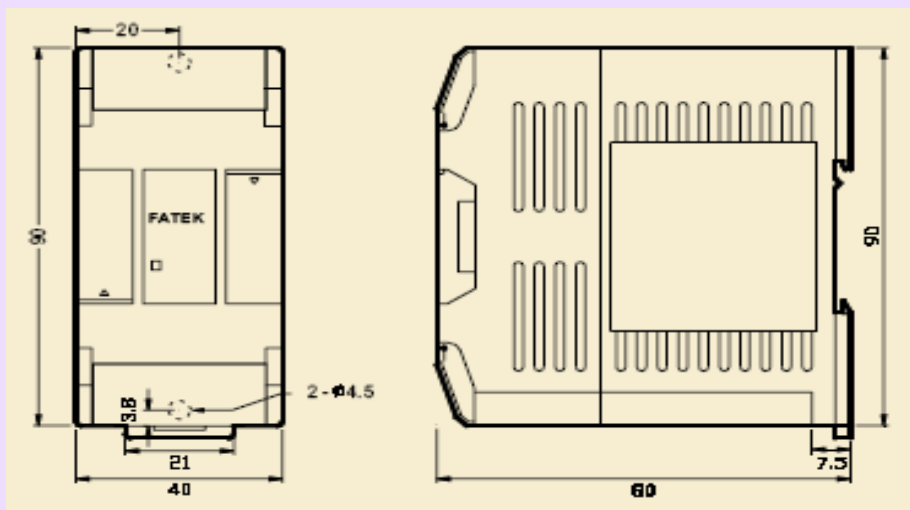

FBs-4DA

4 Channels Analog Output Module

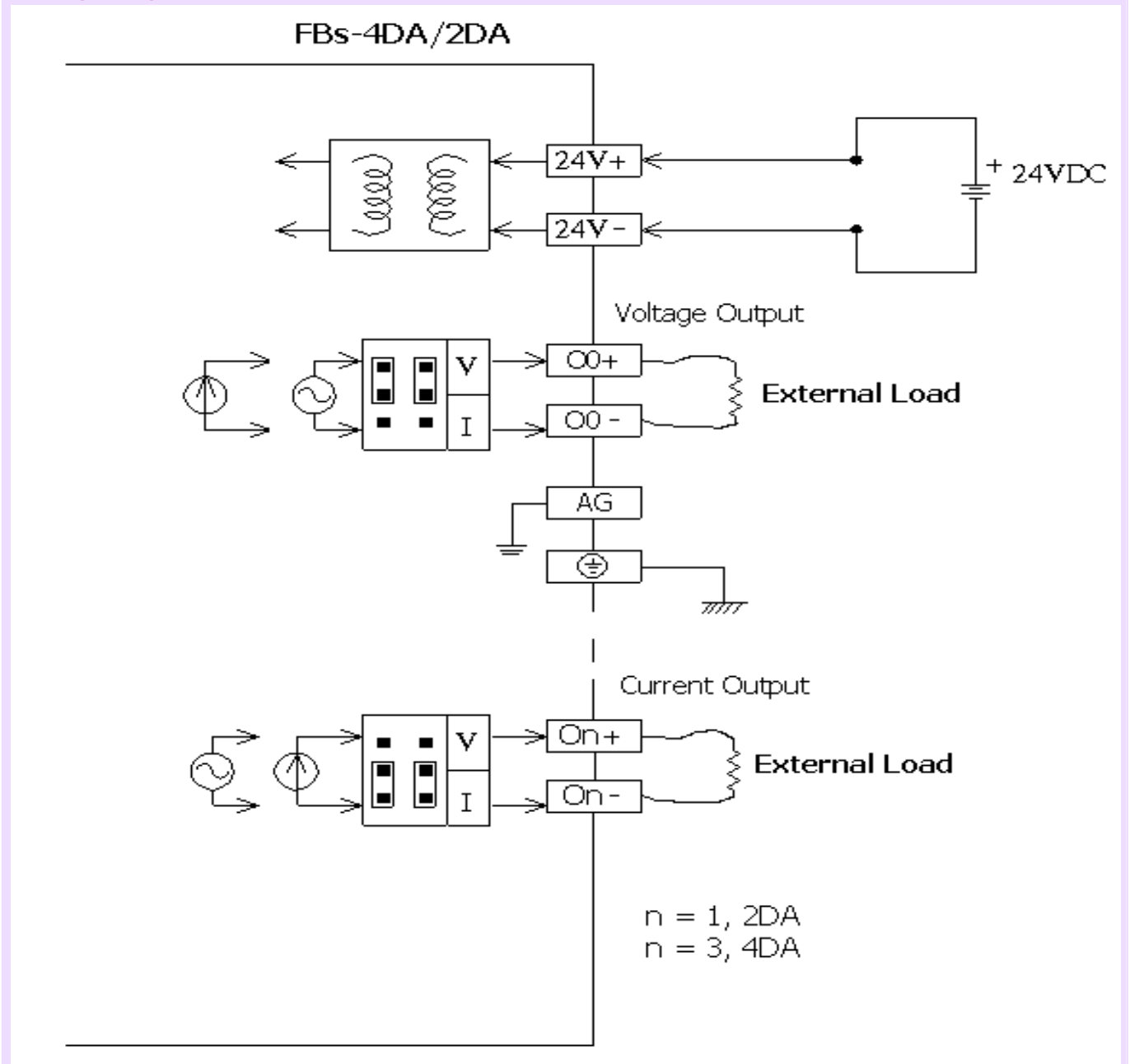

Wiring Diagram



Jumper Setup

Output Code Format Selection

There are two formats of output code can be selected, one is Unipolar and the other is Bipolar. The range of the Unipolar code value is 0~16383 while the Bipolar is -8192~8191. The extreme two ends of the code value corresponding to the minimal and maximal analog output level respectively. For example, if the analog signal is set to -10V~+10V range, for the same code value 0, the Bipolar code will result 0V output, while the Unipolar code will result -10V output, for the code value 8191, the Bipolar code will result 10V output, while the Unipolar code will result 0V output.





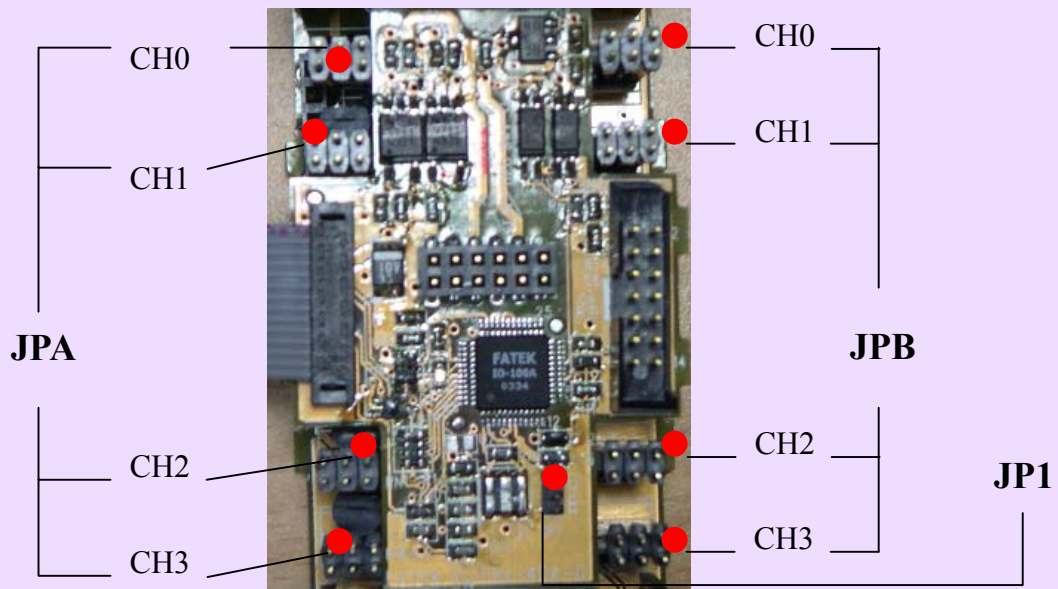

Code Format	Range	JP1 Setting
Bipolar	-8192 ~ +8191	 U B
Unipolar	0 ~ 16383	 U B

Output Signal Type Selection

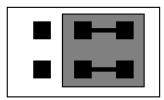
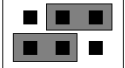
The output signal type of each channel can be set individually. There are two jumpers for each channel to control the output signal type. The corresponding jumpers for each channel are shown at below:

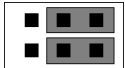
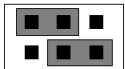
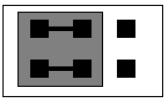

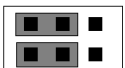
The jumper setting for each type of signal output are shown at below:

Signal Type	JPA Setting V I	JPB Setting <table border="1"> <tr> <td>B</td> <td>U</td> </tr> <tr> <td>10V</td> <td>5V</td> </tr> </table>	B	U	10V	5V
B	U					
10V	5V					
0~20mA						
-20mA~+20mA						
0~10mA						
-10mA~+10mA						
0~10V						
-10V~+10V						
0~5V						
-5V~+5V						

The default factory settings of FBs-4DA/2DA analogue output module are

Output code format – Bipolar(-8192~+8191)

Output signal type and range – Bipolar(-10V ~ +10V)

For those applications that require the setting differ than the above default setting should make some modification according to the tables listed above