

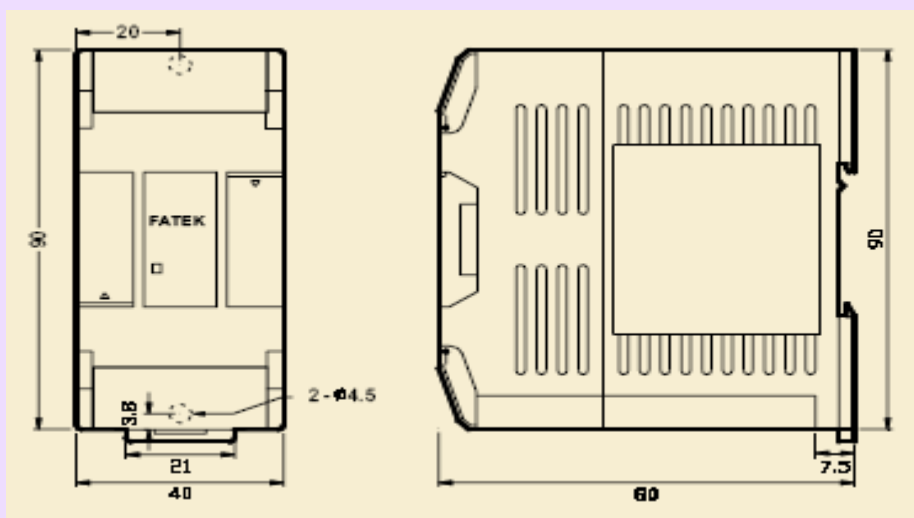

### Introduction

FBs-RZR module is one of the special function modules of FBs PLC family. With this module, the PLC can connect the angular resolver sensor. Thanks to the signal processing chip inside this module, the angle signal of the resolver shaft can be derived in digit format. Unlike the traditional optical encoder, the resolver can be withstood highly with the shock, oil and the dust. For this reason, it can be used in harsh working environment. For example, The press machine, noted for its high shock during operation, is a typical application for resolver.

### Outline



### Specification

**Angle resolution** – 1 part of 1440 (0.25 degree)

**Resolver excitation frequency** – 10 KHz

**System interface** – RS485 serial communication

**Data update rate**- Around 600 Hz

**PLC application port** – port2 or port4

**Program interface**- Interrupt or scanning, executes the HSCIO interrupt subroutine if interrupt mode is enabled.

**Installation capability** – One RZR module per PLC system

**Indicator**- 5V power LED

**Internal power consumption**- 5V, 100mA

**Operating temperature**- 0 ~ 60 °C

**Storage temperature**- -20 ~ 80 °C

**Size**- 40(W)x90(H)x80(D) mm

### Wiring

#### Upper part signal

Signal label	Description
RT+	Positive line of RS485 transceiver signal
RT-	Negative line of RS485 transceiver signal
GND	RS485 signal ground

#### Lower part signal

Signal label	Description
S4	S4 signal of COS winding
S3	S3 signal of SIN winding
S2	S2 signal of COS winding
S1	S1 signal of SIN winding
R2E	Excitation reference signal for R2 line
R1E	Excitation reference signal for R1 line
GND	Signal ground for resolver. Can be connected to shield of signal cable

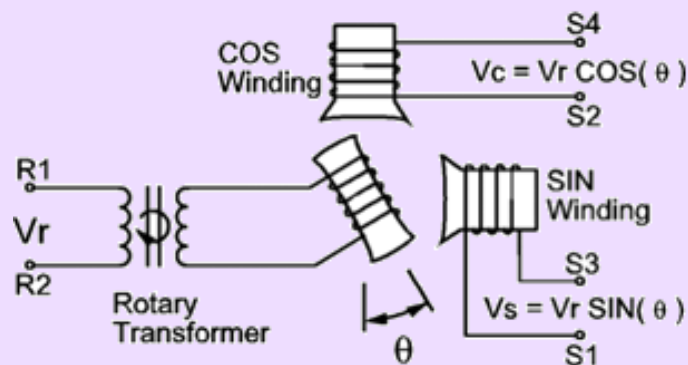

### Setup

**PLC\*<sub>1</sub> communication port setup**– Can use the port2 or port4 to connect RZR module. This setup involve the R3992setting(Refer the following description). When finish the setup the PLC will initialize the communication parameter of associate port as follow

Parameter	setting
Baud rate	38400
Parity check	EVEN
Data bit	8
Stop bit	1

**PLC communication protocol setup** – The communication protocol of attached port should be set to “Fatek Communication protocol”, otherwise the communication will be failed.

### Program interface

#### Configuration register

Register	Description
R3992	Should set to one of the following values ,otherwise the RZR module will not processed by PLC = 5AA5H, use port2 to connect RZR module = 5AA6H, use port4 to connect RZR module
R3995	Angle compensation value. Fill the non-zero value if the zero reference angle of resolver and machine is not aligned. Range: -359~359 degree
M1943	Use this bit to control if it should execute the HSCIO interrupt subroutine whenever the angle value is updated =0, not execute HSCIO interrupt subroutine =1, Execute HSCIO interrupt subroutine once if angle value is updated

#### Status register

R3993	Error status of RZR module. High byte is error code, low byte is error count. High byte will reflect the current error status, it will be cleared immediately whenever the error is not present. =01h~0Fh, communication error between PLC and RZR module =10h, resolver wiring error =20h, PLC has received a error message =FFh, no communication between PLC and RZR module
R3994	If the error status in R3993 is not zero, the content of R3993will be transferred to this register. The value of this register will not be cleared unless the ladder instruction is executed to do so.
R3996	Current angle value. The calculation of this value has put the compensation angle in R3995 into consideration. It will be only updated when PLC is under RUN mode. Range: 0 ~ 359 degree
R4096	Conversion raw data of resolver decoder output. Range: 0~ 1439 (map to 0~359 degree). Refer this value if the angle resolution better than 1 degree is required (360/1440 = 0.25degree). The calculation of this value do not put the value in R3995 into consideration. It will be only updated when PLC is under RUN mode.

\*<sub>1</sub>: Only the PLCs with OS version not older than V4.73 support the FBs-RZR module